

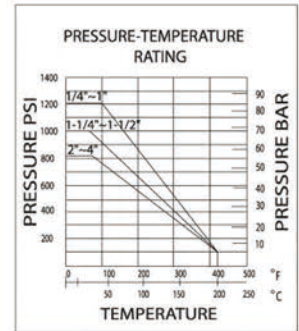

SP3PBSPDM

- SS316
- Investment Castings For Body And Cap
- Internal Entry Blow-Out Proof Stem
- Mounting Pad: ISO5211
- Pressure Rating: 1000PSI (PN63)
- Threaded Ends: ANSI B2.1, BS 21, DIN 259/2999
- Material: CF8M, CF8, CF3M, WCB
- Pressure Test : API 598



MATERIAL LIST

ITEM	PART	MATERIAL	QTY
1	BODY	CF8M	1
2	BALL	SS316	1
3	BALL SEAT	R-PTFE(15%)	2
4	THRUST WASHER	PTFE	1
5	BALL GASKET	PTFE	2
6	O-RING	VITON	1
7	STEM PACKING	PTFE	1
8	GLAND	SS304	1
9	TAB WASHER	SS304	1
10	STOPPER	SS304	1
11	SPRING WASHER	SS304	1
12	STEM	SS316	1
13	NUT	SS304	1
14	HANDLE	SS304	1
15	HANDLE COVER	PLASTIC	1
16	WASHER	SS301	2
17	SPRING WASHER	SS304	4(12)
18	NUT	SS304	4(12)
19	BOLT	SS304	4(6)
20	CAP	CF8M	2

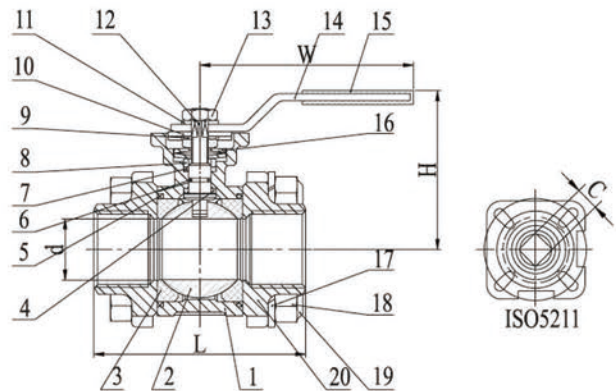

DIMENSION TABLE

SIZE	d	L	H	C	W	ISO5211	N.M	KGS
1/4"	11	47	59	9	120	F03	4	0.41
3/8"	12.5	47	59	9	120	F03	4	0.40
1/2"	15	54	63	9	120	F03	5	0.45
3/4"	20	73	70	11	140	F04/F05	8	0.86
1"	25	79	74	11	140	F04/F05	10	0.86
1-1/4"	32	90	88	14	204	F05/F07	14	1.88
1-1/2"	40	102	94	14	204	F05/F07	18	2.78
2"	50	118	102	14	204	F05/F07	25	3.56
2-1/2"	65	149	140	17	255	F07/F10	48	7.20
3"	80	180	153	17	255	F07/F10	75	12.10
4"	100	223	166	17	302	F07/F10	110	19.90